

SHW910X1

90CM WALLMOUNT CANOPY RANGEHOOD



EAN 345025001733

Finish	stainless steel
Dimensions	898mmW x 640-1130mm H x 470mmD
Installation	wallmount
Motor	1 x 250W
Max Airflow	920m ³ /hr (IEC 61591)
Noise rating	52-71 dBA (IEC 60704-3)
Illumination	2 x 2W LED
Speeds	four
Delay stop	n/a
Supplied Accessories	3 x stainless steel grease filters
Optional Accessories	charcoal filter part #112.0157.240
Ducting Options	duct to atmosphere / recirculate — 150mm diameter ducting required
Power	220-240V, 50Hz 10A (3-pin plug)
Warranty	two years parts and labour

SHW910X1
90CM WALLMOUNT CANOPY RANGEHOOD

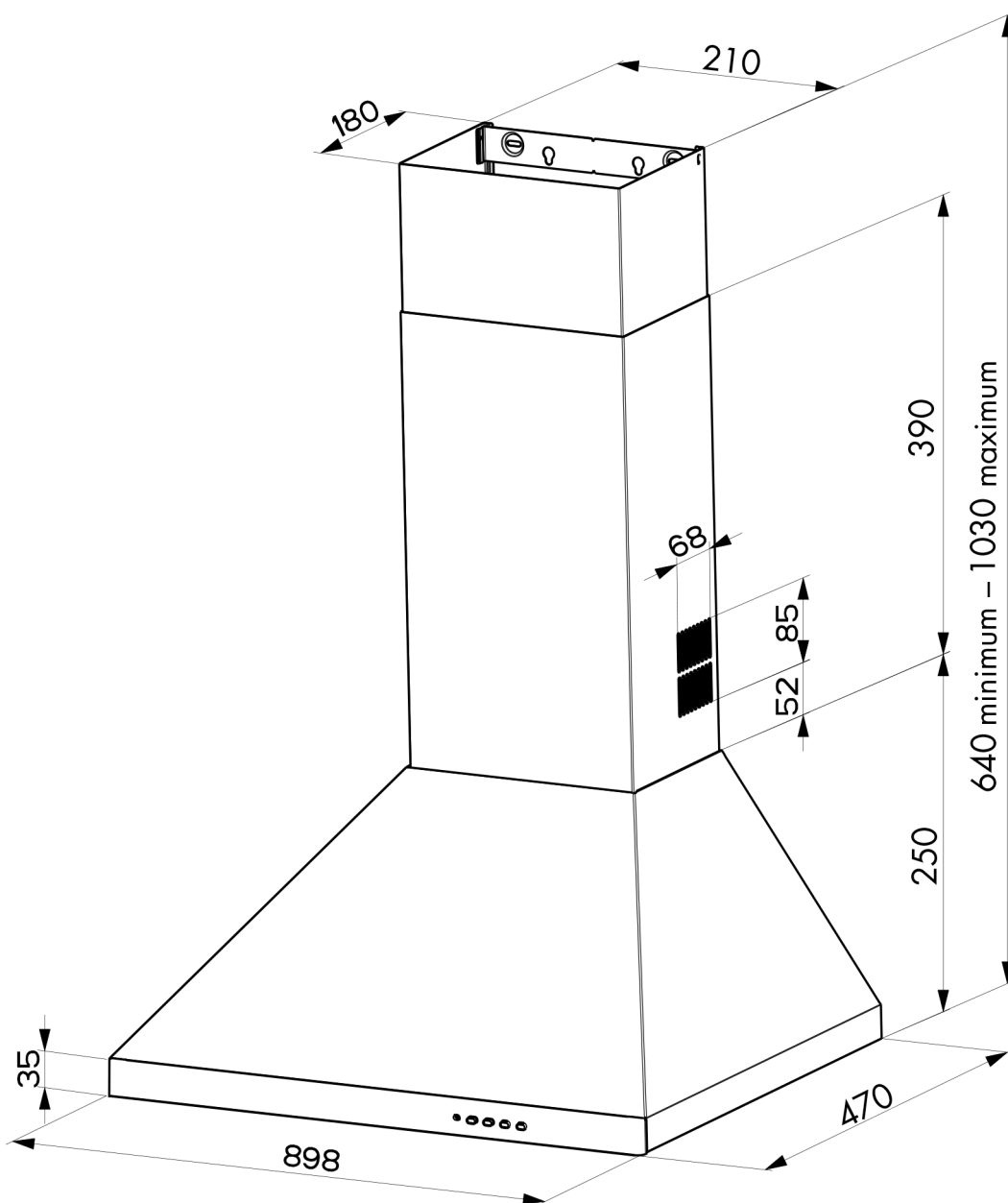

PLEASE NOTE: drawings are not to scale. They are to assist only.
WARNING: technical specifications and product sizes can be varied by the manufacturer without notice.
Cutouts for appliances should only be by physical product measurements. The above information is indicative only.